

# Pumps, Pumping Systems and Ancillaries

## NEWTON NP750

### Clean Water Pump

Rev 1.0 - 13 May 2020

PRODUCT CODE - P5 &amp; P6

### INTRODUCTION

Congratulations on your purchase of this pump product. All Newton pump products are developed with the help of the latest technologies and manufactured with the most advanced electrical/motor parts.

Please check the following points upon receipt of your pump:

1. The pump is the model that you ordered.
2. Has any damage been caused during delivery?
3. Are the pipe/valve ancillary parts you asked for included as requested?

Please take the time to read these instructions carefully before using the appliance.

### SPECIFICATIONS

| Output | Discharge | Rated    |            | Maximum  |            | Dimension   | Weight |
|--------|-----------|----------|------------|----------|------------|-------------|--------|
| (W)    | BSP       | Head (M) | Flow (LPM) | Head (M) | Flow (LPM) | LxWxH (mm)  | Kg     |
| 750    | 2"        | 4        | 320        | 12.5     | 360        | 236x173x380 | 8.5    |

Check the nameplate for your pump's specification as the table above. Be careful not to exceed the given specifications in the use of your pump.

### LIMITATIONS

The Newton NP750 is suitable to pump clean water with suspended soft solids of up to 35 mm. The pump can be used for both permanent and temporary installation. Do not use for the pumping of sewage. Do not let the pump run dry. The pump cannot be used for sea water and inflammable, corrosive, explosive or dangerous liquids.



**DANGER:** Keep the equipment out of the reach of children

**DANGER:** Failure to follow the directions given could cause serious risk to individuals or property



**WARNING:** Failure to follow an instruction may damage the pump and/or the system

### INSTALLATION - IMPORTANT

- Pump(s) must receive power directly from a fused switched spur that is in line of site of the pumping station. Do not connect the pump to extension cables
- If possible, each pump should have its own connection to the consumer board and be protected by a 30 mA RCD
- Use the correct size fuse for the pump as confirmed on page 2

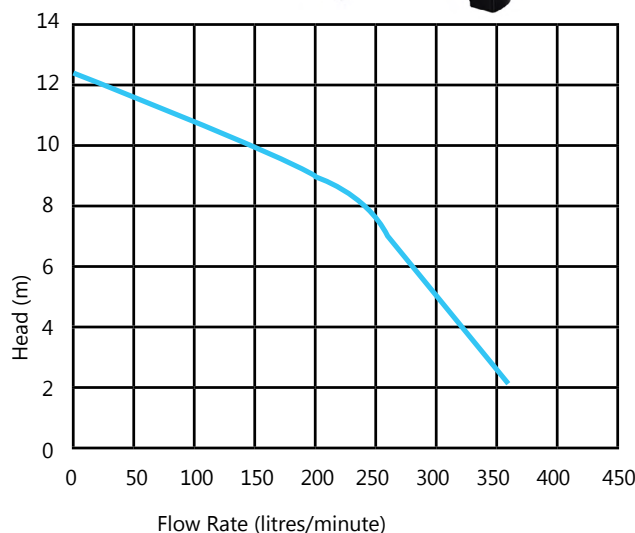

# NEWTON NP750

## Clean Water Pump

### INSTALLATION

- Do not work on the pump until power is disconnected
- Do not cut off ground pin or use an adaptor fitting
- Do not use an extension cord
- Before installing or servicing this pump, be certain the pump power source is disconnected
- Installation and electrical wiring must be carried out by trained and qualified personnel
- Pump must be correctly earthed
- Voltage of power supply must match the voltage of the pump
- Before installing the pump, clear the sump basin of any water, debris or sediment

The following may cause severe damage to pump and will void warranty:

- Using extended wiring not suitable for the pump motor size and the distance of the extended cable
- Not having the pump correctly grounded to earth
- Working on the pump without it being disconnected
- Running the pump continuously
- Pumping chemicals or corrosive liquids
- Pumping gasoline or other flammable liquids
- Do not use the pump if it is damaged

#### Overload protection:

The Newton NP750 includes a built in thermal protection switch. The pump stops if an overload condition occurs. The motor restarts automatically after it has cooled down.

#### Electric Supply:

The NP750 pump requires a single phase 230V AC power supply. It is advisable that all pumps are connected to their own individual power supply directly from the consumer board so that each of the pumps does not share a consumer board supply with the other pump or with any other electrical circuit or device. In reality, this is normally only achievable with new build properties or where fundamental refurbishment of the whole property or the electrical supply is to be undertaken.

Where it is not planned or possible to have each pump connected to a separate supply from the consumer board, it is preferable that each pump is supplied from a separate circuit. If this is not possible, each pump should be connected to a separate fused and switched spur or socket. Each separate circuit should have its own RCD protection as required by the 17th Edition Wiring Regulations. The RCD should be correctly sized at 30mA so as not to trip during normal pump start or pump run parameters.

It is preferable for the pumps to be wired to the rear of a switched spur. The spur should be switched and have a neon light confirming the 'ON' position. Pumps may be plugged into wall sockets and again these should be switched and have neon light notification of the 'ON' position. It is recommended that the spur or socket have a label confirming that the switch must not be switched off unless in an emergency.

The spur or socket should be fitted with the correctly sized fuse appropriate to the motor size of the connected pump: NP750 - 13 amps.

The spur or socket should be located in direct eye sight line of the sump and to the wall closest to the sump so that in an emergency it is obvious which switch will turn off the pumps.

### SUPPLIED FITTINGS & PIPE INSTALLATION

The Newton NP750 has a 2" BSP threaded female outlet ready to receive pressure rated pipe and pipe fittings. 50mm or 63mm (recommended) pressure rated pipes are suitable. Fit the pump into the sump chamber with correctly sized and cut pipework and pipe fittings, ensuring that the pipe build includes a means of removal of the pumps for servicing and repair.

The NP750 is not supplied with a one-way-valve and so the valve, if required, must be ordered when the pump is purchased. The one-way-valve, pressure rated pipe and pipe fittings should be ordered with the pump. Please see pipe and valve options and pipe fittings on the [product data sheet](#).

# NEWTON NP750

## Clean Water Pump

### ELECTRICAL PRECAUTIONS



Before servicing a pump, always shut off the main power breaker and then unplug the pump.  
Make sure you are not standing in water and are wearing insulated protective sole shoes.  
Connection or disconnection of the pump from the electrical supply should be by trained & qualified persons only.

### TROUBLESHOOTING - DISCONNECT PUMP FROM MAINS & CONVERTER POWER SUPPLY

| PROBLEM   | POSSIBLE CAUSES   |
|---|---|
| Pump motor hums but no water is being pumped                  | <p>Impeller may be clogged. Free impeller from debris.</p> <p>The check valve may have been installed in the wrong direction. Ensure arrow on valve is pointing in direction of flow.</p> <p>Discharge shut-off valve (if used) may be closed.</p> <p>Pump could be air-locked. Start and stop several times by raising and lowering the switch.</p> <p>Check for clogged vent hole in pump case.</p> <p>Float may be set too low – pump has removed as much water as it can but cannot switch off. Raise float so that the pump turns off before pumping out all the water it can.</p> <p>NOTE: If all of the above are OK, then the motor winding could be damaged.</p> |
| Pump runs and pumps out of the sump chamber but does not stop | <p>Switch may be caught and so unable to reach the 'OFF' position. Make sure switch is unhindered in its operation.</p> <p>Possible defective vertical switch. Speak with Newton Waterproofing Systems with a view to replacing the vertical switch.</p> <p>Float may be set too low – pump has removed as much water as it can but cannot switch off. Raise float so that the pump turns off before pumping out all the water it can.</p>  |
| Pump runs and pumps out of the sump chamber but does not stop | <p>Pump could be air-locked. Start and stop several times by raising and lowering the switch.</p> <p>Float may be set with a too narrow band between 'ON' &amp; 'OFF'. Reset float so that the pump turns on and off to remove the optimal volume of water.</p> <p>The base of the pump could be clogged. Clean the base of debris.</p> <p>Impeller or volute opening maybe fully or partially clogged. Remove pump and clean the opening.</p> <p>Pump impeller could be partially clogged with matter, causing motor to run slow and overload. Remove pump and clean.</p>  |
| Fuse blows or circuit breaker trips when pump starts          | <p>Pump impeller or impeller housing may be partially clogged with foreign matter, causing motor to run slow and overload. Remove pump and clean.</p> <p>Motor starter may be defective.</p> <p>Fuse size may be too small. Use a 13 amp fuse.</p> <p>Circuit breaker could be too sensitive. Use 30mA breaker.</p> <p>Check the fixed wiring from the spur to the consumer board</p> <p>Check all wiring from the pump(s) to the spur, including the control panel, if fitted.</p>   |
| Motor runs for a short time, then stops                       | <p>Inlet openings in pump base may be clogged. Remove pump and clean the openings.</p> <p>Pump impeller may be partially clogged with foreign matter, causing motor to run slow and overload. Remove pump and clean.</p> <p>Motor starter may be defective.</p> <p>Impeller may be fully or partially clogged. Remove pump and clean.</p>   |

# NEWTON NP750

## Clean Water Pump

### STRUCTURE & PARTS LIST

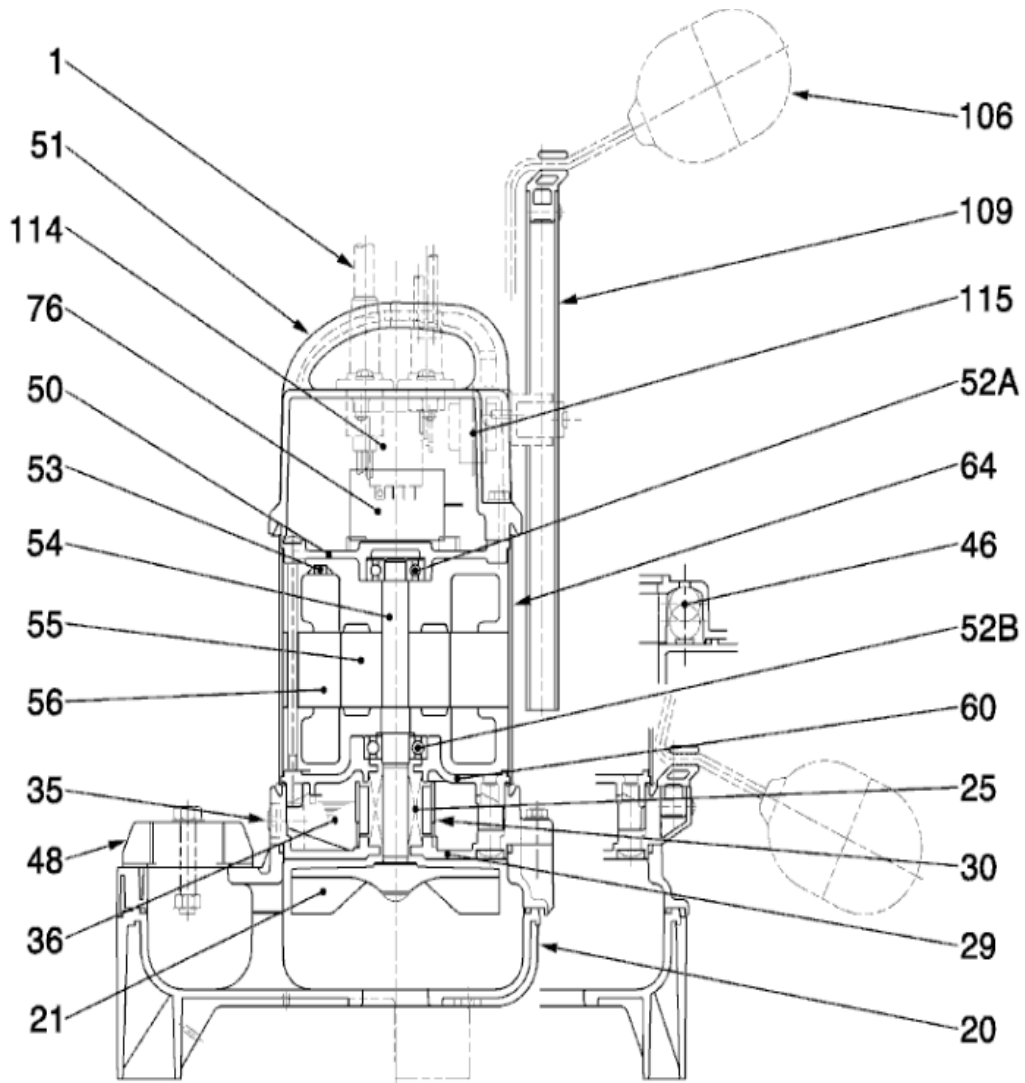

50PUA2.75S-53

| No. | Description  | Remark                  | No. | Description       | Remark                  |
|-----|--|-------------------------|-----|-------------------|-------------------------|
| 1   | Cable  | H07RN-F                 | 55  | Rotor             | .                       |
| 20  | Pump casing  | ABS-GF20                | 56  | Stator            | .                       |
| 21  | Impeller   | PPO-GF20                | 60  | Bearing Housing   | Aluminium die casting   |
| 25  | Mechanical seal                                      | W-14HL                  | 64  | Motor Frame       | SUS304 (EN-X5CrNi18-10) |
| 29  | Oil casing   | PPS-(GF+MD)50           | 76  | Condenser         | .                       |
| 30  | Oil distributor                                      | Plastic                 | 106 | Float switch (2x) | ABS                     |
| 35  | Oil screw  | SUS304 (EN-X5CrNi18-10) | 109 | Support           | PVC                     |
| 36  | Lubricant  | Turbine oil (ISO VG32)  | 114 | Relais            | .                       |
| 46  | Air vent valve                                       | Glass bead              | 115 | Transformer       | .                       |
| 48  | Screwed Flange                                       | PC(PBT-GF30)            |     |                   |                         |
| 50  | Motor cover  | Steel plate             |     |                   |                         |
| 51  | Main cover   | Product overview        |     |                   |                         |
| 52A | Upper bearing  | 6201ZZC3                |     |                   |                         |
| 52B | Lower bearing  | 6302ZZC3                |     |                   |                         |
| 53  | Motor Protector 380/400/415V-50Hz KA314-HRXL00 (H.C) |                         |     |                   |                         |
| 54  | Shaft  | SUS304 (EN-X5CrNi18-10) |     |                   |                         |

# NEWTON NP750

## Clean Water Pump

### GUARANTEE

The right to claim under guarantee must be proven by the purchaser by presentation of the purchase invoice.

Note:

- Should your equipment not function correctly, please firstly check whether this is due to other reasons, e.g. interruption of the power supply or incorrect handling are the cause
- Please do not return goods to Newton Waterproofing Systems unless accompanied by proof of purchase and a Newton Returns Form. The form should be correctly and fully completed

### LIMITED WARRANTY

Newton Waterproofing Systems will repair with new parts or replace the pump if proven to be defective due to materials or workmanship.

Newton Waterproofing Systems shall possess the sole right to determine whether to repair or replace defective equipment, parts or components.

**PUMPS:** Newton NP Pumps are supplied with a 3-year manufacturers warranty from the proven date of installation or the date of purchase if this cannot be verified. A 5-year warranty is available if the pumps are serviced at intervals agreed by a Newton approved service engineer. In all cases, the warranty is 'back-to-base'. Newton Waterproofing Systems have a returns policy and any issues regarding pumps under warranty should, in the first instance, be referred to our Head Office by contacting 01732 360 095. Please see our Terms & Conditions of Sale for further information.

**LABOUR & COSTS:** Newton Waterproofing Systems shall in no event be liable for the cost of field labour or other charges incurred by the customer in removing and/or re-affixing any Newton pump product, parts or components.

#### THE WARRANTY WILL NOT APPLY:

- to defects or malfunctions resulting from failure to correctly install, operate, or maintain the pump in accordance with printed instructions provided
- to failures resulting from abuse, accident or negligence
- to normal maintenance services and the parts used in connection with such service
- to units which are not installed in accordance with applicable local codes, ordinances and good trade practices
- if the unit is used for purposes other than for what it was designed and manufactured for

Newton Waterproofing Systems reserve the right to update product literature at any time. Please always refer to our [website](#) for the latest versions.