

Newton Titan

Compact Pumping Systems

Revision 1.1 - 17th July 2023

INTRODUCTION

The *Newton Titan* is a compact sump chamber for the collection of surface and ground water. The unique octagonal sump shape ensures structural stability and provides eight large surfaces for inlets into the pump of up to 110mm via an optional wall flange. The sump chamber also features a flared base to prevent flotation. The compact size means that the Titan is ideally sized for confined spaces such as light wells and small cellars. The Titan sump can be used with single pumps or twin pumps via a single discharge line. Please see below for details of the pumping systems built with the Newton Titan chamber.

PUMPING SYSTEMS & PURCHASE CODES

Titan Sump Chamber		
		Purchase Code
Chamber only		T2C
Chamber plus lid & frame		T2C&L

Built Pumping Systems		
Pump(s)	Number of pumps	Purchase Code
CP150	1	T1
CP250	1	T2
CP250	2	T3
CP400	2	T4

The recommended discharge is 50mm. **NOTE:** Pipe and pipe fittings should be ordered at the same time as the pumping system as these items are not available on the high street or at builders merchants.

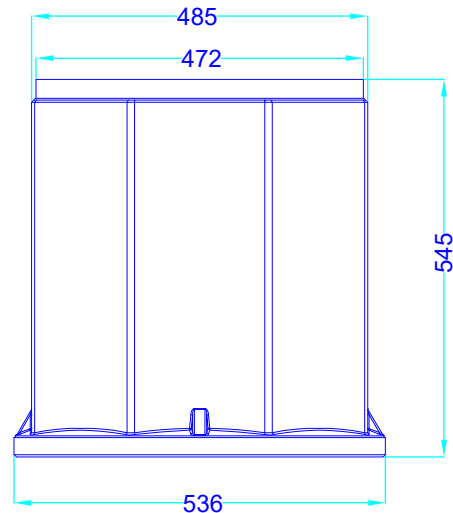
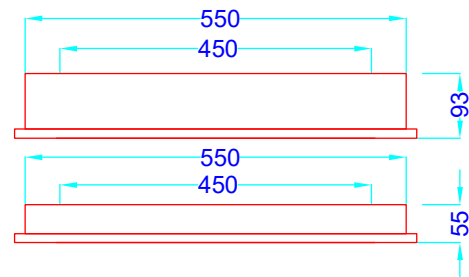
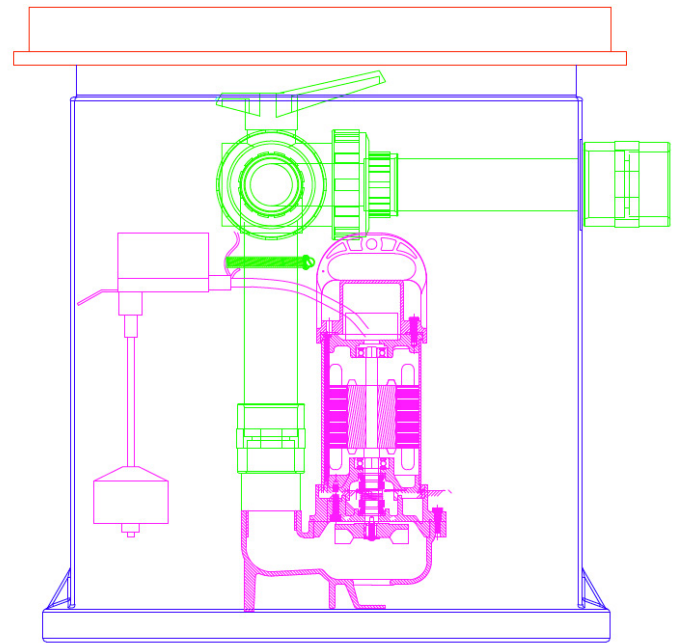
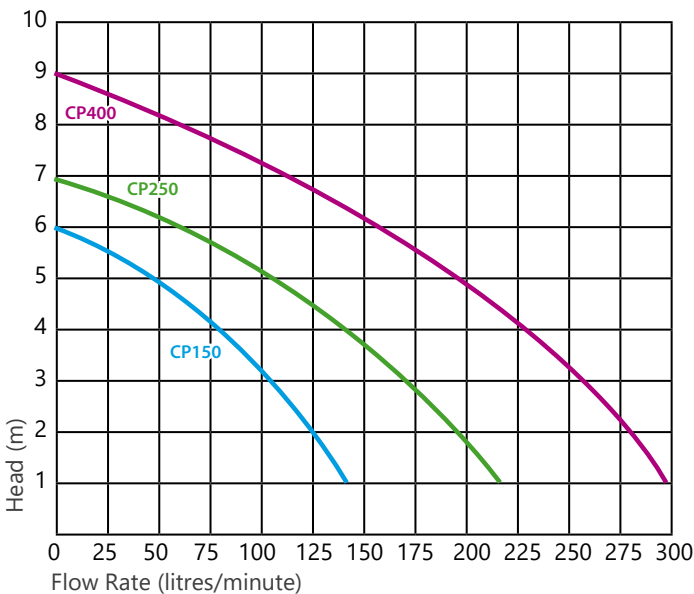

SYSTEM PARTS

Included within the system packaging is:

- 1 x Locked & Sealed Lid & Frame with 46mm recess
- One or two Newton CP pumps as ordered
- 1 x check valve per pump. The valve has a BSP thread to the top and the bottom of the valve and screws directly into the pump. A 1 ½" BSP to 50mm socket is supplied with each valve. This screws into the top of the valve to provide a socket ready for the supplied internal pipework
- 50mm pressure-rated pipework including a shut-off valve. Single pump systems have a single 'in-line' shut-off valve and twin pump systems have a three way shut-off valve to allow for disconnection of one pump whilst the other is still operational
- 1 x sump wall discharge assembly that terminates to a 50mm socket outside of the sump ready for 50mm pressure rated pipe
- 1 x PA50 High Water Level Alarm

Please note: Conduit, vent, rising main pipe, fittings and solvent weld glue is not supplied but required for the installation. Details of conduit, drainage kits and their required wall flanges can be found on page 4 of this document.

- The sump is supplied with a 50mm internal pipe and fittings already fitted, terminating to a 50mm female uPVC socket at the chamber wall, ready to receive 50mm uPVC rising main. Rising main pipe is not included and will need to be ordered - see page 4 for information on rising main pipe and fittings.
- Holes for connection of drainage pipes into the chamber and for connection of conduit and vent (if required) are not included and these should be cut on site by the installing technician.

TYPE C - CDM WATERPROOFING SYSTEMS

The Newton CDM range of pumping systems are designed to be used with the Newton CDM, Type C, [cavity drain waterproofing system](#). The CDM pumping systems include everything needed to enable simple 'plug-and-play' connection of incoming drainage and outgoing rising main and electrical conduit, with all connections into and out of the sump always at the same height, regardless of the depth of the floor build.

To use the Titan pumping systems with the Newton CDM waterproofing system, the ancillaries listed in the CDM section on page 4 will need to be purchased separately.

CONDUIT

Pumps power cables are high voltage. Alarm and float cables are low voltage.

NOTE: Low voltage and high voltage cables should not use the same conduit. A conduit kit is available. If conduit is installed by other means, wall flanges and holes cutters are available, see page 4 for further details.

VENT

In most cases, the incoming drainage connection acts as a vent and so additional vents are not required.

If the system is sealed, and air cannot enter the chamber via the drainage-in connections, a dedicated vent pipe will be needed. A convenient way to do this is to use the same 50mm pipe and fittings as used by the rising main, passing through the wall of the chamber via a 50mm wall flange. Please see page 4 for further information.

HEALTH AND SAFETY AT WORK

The dangers of working with water and electricity pose severe threats to health if obvious and fundamental precautions are not taken. Therefore if you are in any doubt to any of the following, please do not hesitate to contact us.

SUMP INSTALLATION - NOTES

This HDPE chamber is a liner and must always be supported by a concrete base and surround of adequate thickness for the ground conditions. The chamber requires a minimum of 100mm of good grade concrete surrounding it to prevent buoyancy.

When installed in basements or cellars, if possible, form a concrete box of the same section width and quality of the slab/raft the sump is to be placed within. Construction joints should be waterproofed in the same way as the those within the rest of the concrete structure.

- 1) Select a suitable location for the chamber. Ensure that the sump lid is accessible once the finishing works are complete. Pay particular attention to the proposed line of stud and block walls that may be built after the sump installation
- 2) Check that no underground cables, pipes or service ducts lie beneath
- 3) Ensure that sufficient space is available to receive the chamber, pipe work and surrounding concrete.

BEFORE SUMP INSTALLATION

- Ensure that all the parts required for the installation are at hand, including wall flanges, hole cutters, pipe and fittings, glue etc
- The installation cannot be fully completed without the required parts
- Write down a list of the parts you think are required and check that you have these available. If you are unsure as to what you need, please speak with Newton and we will be happy to chat this through with you
- Please see page 4 for list of parts

SUMP INSTALLATION

STEP 1:

1. Excavate a hole or create a concrete box within the floor ready for the sump chamber. The hole or box should be at least 200mm larger diameter than the Titan chamber to allow for sufficient concrete to surround the chamber to prevent flotation. Where the sump is to be installed within a structural slab, an engineer should advise on the volume and mass of concrete surrounding the chamber. The depth of the excavation or concrete box will depend on your finished floor height. Create a supporting base with a minimum of 100mm of concrete which is of a consistency that will support the chamber during the levelling process

STEP 2:

1. Place the sump chamber into the excavation with the base directly on to the freshly placed concrete base. Rotate the chamber so that it will match with your desired inlet connections and your preferred discharge pipe location. Use a long builders level and adjust the chamber so it is level
2. Place and then compact about 200mm of concrete to the sides of the chamber and the excavation. With each 100mm of concrete placed, place an equivalent depth of water into the sump chamber. Keep checking the level and height periodically and adjust if necessary. Let the concrete go off sufficiently so that the sump is locked in place and then go to Step 3

STEP 3:

1. Cut the holes ready for conduits, vent if needed and the required number of drainage inlets at the required locations, and fit the wall flanges
2. Fit all pipes entering and exiting the sump
3. Run the Alarm cable and pump cables through the separate conduits. If the Pump(s) and Alarm are not on site, run a pull cable through the two conduits ready for pulling through the cables when they are ready to be fitted
4. Connect 50mm pressure pipe to the outlet socket. Use a 90 degree elbow at the wall if the pipe is to rise vertically at this point. Continue with pipe fitting to final connection if possible, but at a minimum the vertical pipe should extend higher than the finished floor level by about 100mm. Once all pipe work is cut to the correct size, clean, abrade, chamfer and glue the pipe parts with uPVC solvent weld glue
5. Fill the sump with water and then concrete around the sump to match the slab. When the concrete is cured, drill a ring of 6mm holes around the chamber at slab level 50mm intervals to capture water that may squeeze up between the sump and the concrete surround

PUMP INSTALLATION - PIPE AND FITTINGS

The pipe and fittings are pre-cut and pre-glued. The only way that the pipe can be screwed into the pumps is by unscrewing the pipe-work at the shut-off valve.

1. Screw the one-way valve(s) into the Pump(s), ensuring that the direction arrow is facing upwards. With CP400 pumps, the reducing adaptor must be screwed into the pump first
2. The glued pipe can then be screwed onto the upper thread of the one-way valve
3. Screw the vertical
4. Reconnect at the shut-off-valve
5. Dry fit the pipe and fittings to ensure correct fitment. Make adjustments as required
6. Remove the glaze from the pipe ends and inside of the sockets with sand-paper or uPVC Pipe Primer
7. Chamfer the pipe ends with a pipe chamfering tool
8. Apply glue into the socket and onto the pipe ends and carefully insert the pipe end into the sockets, slightly twisting the pipe as it is inserted. Insert fully, using pressure, and hold for at least 30 seconds
9. Remove excess glue with a slightly damp cloth
10. Leave for one hour before testing the pipe

ELECTRICAL CONNECTION

The pumps should be installed by a competent person in accordance with Part P of the building regulations.

Pumps should not be fitted to either grid mains or Control Panels or Inverter Battery Back-Up, until after the applicable product Installation Manual has been consulted and the electrical requirements and methods of connection are fully understood. Use the instructions within the applicable manuals to make final electrical connections.

BATTERY BACK-UP SYSTEMS

The following battery back-up systems are available for to ensure continued pumping during power outage:

Matched Battery Back-up Systems				
Pumping System	Pump size (watts)	Inverter	Battery	Purchase Code
T1, T2, T3	150 to 250	12/500/20	40 Ah	BBS1
T1, T2, T3	150 to 250	12/500/20	60 Ah	BBS2
T1, T2, T3	150 to 250	12/500/20	100 Ah	BBS3
T4	400	12/800/35	40 Ah	BBS4
T4		12/800/35	60 Ah	BBS5
T4		12/800/35	100 Ah	BBS6

Please refer to the [Newton Victron MultiPlus TDS](#), and the installation manual and Quick Install Guide within the inverter packaging.

ANCILLARIES

ITEM	Product Code
<i>uPVC Pressure Rated Discharge Pipe</i>	
50mm Pipe - 2.5 m lengths	PP1
50mm 90 degree elbows	PP2
50mm 45 degree elbows	PP3
50mm female-female sockets	PP4
50mm Tee	PP5
50mm wall mount clips	PP6
1½" BSP to 50mm Hosetail	PP28
1½" BSP to 50mm Socket	PP43
uPVC Solvent-on Wet 'R Dry - 240ml	G2
uPVC Pipe Primer - 473ml	G3
<i>Alternative Frame and Lid</i>	
Galvanised steel frame recessed lid with 450 x 450mm opening	TPSL2
Stainless steel edged recessed lid with 450 x 450mm opening	TPSL3
Brass edged recessed lid with 450 x 450mm opening	TPSL4
Aluminium edged, triple-sealed recessed lid with 450 x 450mm	TPSL7
<i>Wall Flanges</i>	
Wall flange for 50mm diameter vent and conduit pipe	WF50
Wall flange for 63mm inlet	WF63
Wall flange for 110mm inlet	WF110
<i>Hole Cutters</i>	
82mm Hole Cutter for 50mm wall flange	HC82
95mm Hole Cutter for 63mm wall flange	HC95
140mm Hole Cutter for 110mm wall flange	HC140
Arbor for hole cutter	PA33
<i>CDM</i>	
Basedrain Connection Kit - Basedrain Adaptor, 63mm flexi-pipe and 63mm wall flange	D21
<i>Conduit & Vent</i>	
Conduit kit -32mm & 40mm - 50 m of each, including bulkhead connections	TPK5
50mm wall flange - allows 50mm O/D pipe to be used as conduit or Vent	TP03

Newton Waterproofing Systems reserve the right to update product literature at any time. Please always refer to our [website](#) for the latest versions.