

Titan-Pro

CDM Pumping System

Revision 5.5 - 31 March 2026

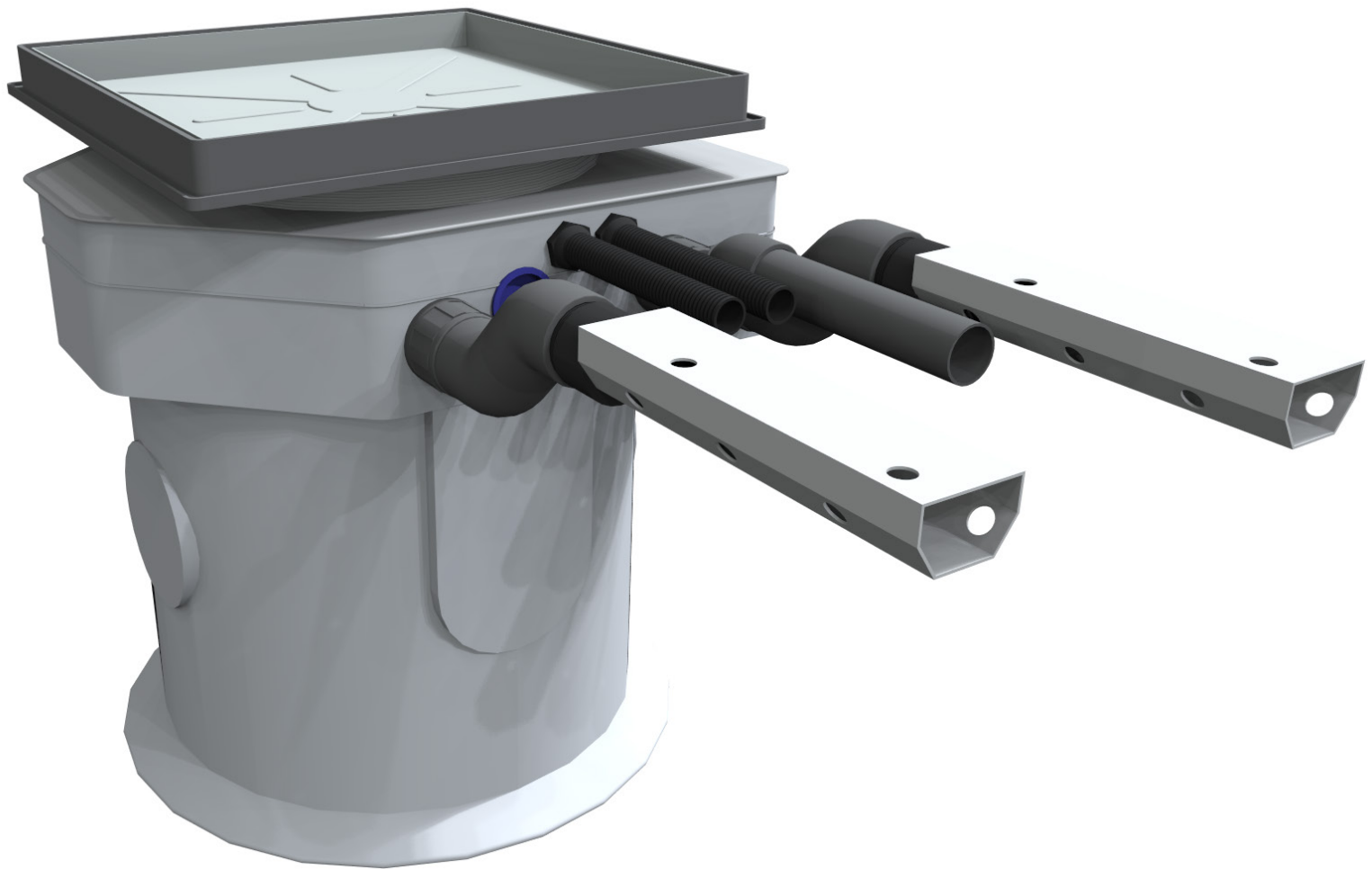

The Titan-Pro Pumping System is designed to be used specifically with our [Newton CDM](#) waterproofing system. It includes components for direct connection with the Newton CDM System drainage channels.

The unique design provides simple connectivity and ease of installation when used with the Newton drainage products; [Newton BaseDrain](#) and [Newton FloorDrain](#), as part of the Newton CDM waterproofing system. The sump chamber is designed to have all the inlet and outlet connections at the same height relative to the Newton drainage products. This is achieved by the sump having a *Fitting Line* to ensure the sump is set at the correct height, and an adjustable neck allowing differences in floor finish height to be taken up by adjustment, and not by physically moving the whole sump up or down to suit.

The recommended discharge is 50 mm, with single and dual rising main options available. 50 mm rising main fits within the 50 mm of the insulated spacer adjacent to the BaseDrain System and above the concrete in most system floor builds. 63 mm discharge is an option for the discharge line(s) if greater pump duty is required, for the [NP750 eco](#) pumps or where the pipe run is longer than usual. **NOTE:** Pipe and pipe fittings should be ordered at the same time as the pumping system as these items are not available on the high street or at builders merchants. If 63 mm discharge pipe is to be used, this must be confirmed at order.

The Titan-Pro is designed to be used with a range of Newton [TAS250](#) Pumps and Newton [NP eco](#) Pumps. All pumps are available in manual versions in order to be compatible with the [Newton Pump Controller](#). Please see individual pump data sheets for further information.

PUMPS FOR CLEAN GROUND WATER AND SURFACE WATER

- [Newton TAS250 - TAS250A & TAS250M](#) - 250W (auto & manual)
- [Newton NP400 eco - NP4A & NP4M](#) - 400W (auto & manual)
- [Newton NP750 eco NP7A & NP7M](#) - 750W (auto & manual)

NOTE - SEWAGE & EFFLUENT

Please use a separate pumping system for the pumping of effluent and sewage. The Titan-Pro is a component part of the Newton CDM cavity drain waterproofing system and should be used to remove ground water and limited volumes of surface water only.

Newton Waterproofing Systems supply a full range of effluent and sewage pumping systems, from small lifting systems to large commercial sewage systems. Please speak with our Technical team for further information

NOTE - T&G FLOOR BOARDS

Where tongue & grooved floorboards are to be used above the Newton CDM floor membrane, there is a slight risk of moisture damage to the boards that are adjacent to the sump lid and frame. To prevent possible moisture damage, seal the circular lower ring of the lid frame to the neck of the Titan-Pro sump with CDM Rope and CDM OverTape.

NOTE - RADON

Where the Newton CDM System is also providing basic radon measures, or full radon measures in conjunction with the Newton PAC-500 System, please ensure that the additional sealing is done as per Newton drawing D31.

Note: 110 mm wall flanges are available for the Titan-Pro on request. See ancillaries on page 6.

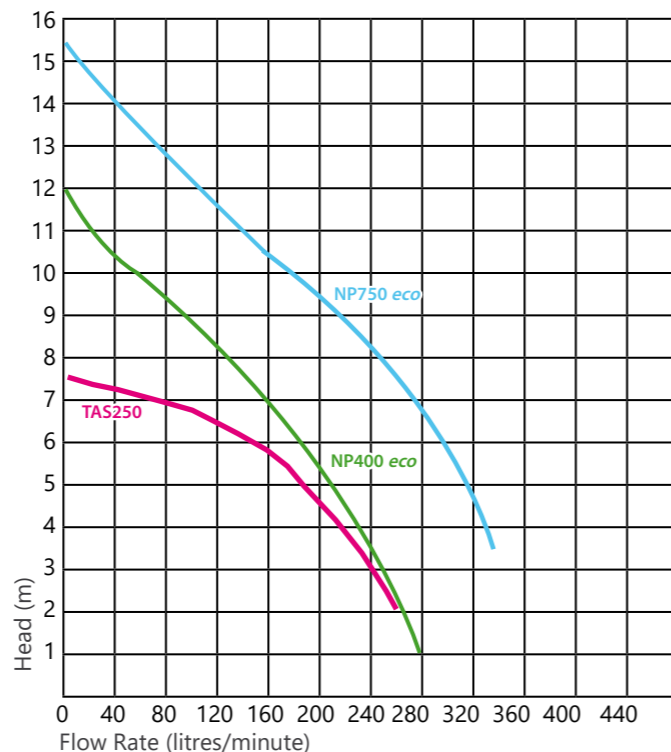

	PAGE
PUMPS	4
SUMP CHAMBER PARTS	5
ANCILLARIES & OPTIONS	6
INSTALLATION - HEALTH & SAFETY	7
INSTALLATION - REFURBISHMENT	8 - 9
INSTALLATION - NEW BUILD - FORMED CONCRETE BOX	10 - 11
INSTALLATION - NEW BUILD - WHERE RECESS FOR DRAINAGE CHANNEL HAS BEEN FORMED	12 - 13
INTERNAL INSTALLATIONS	14

The Titan-Pro pumping system is supplied with single or dual automatic or manual pumps. Dual rising main options are available with the NP750 eco pumps. The following pumps are available:

- Newton **TAS250** - Auto and Manual versions
- Newton **NP400 eco** - Auto and Manual versions
- Newton **NP750 eco** - Auto and Manual versions

Please note that manual pumps must be matched to the Newton Pump Controller.

Automatic pumps are supplied with Vertical Float Switches that allow for very flexible pump switching, allowing for adjustment of the ON & OFF positions of each pump, as well as the overall height of the pump switching.

Please see pump data sheets for further information.

Notes:

1. Twin pump systems are matched pairs to ensure that pump performance is maintained during duty standby operation where the lead pump has failed.
2. Where duty assist pumping may be required to remove larger volumes of ground water, all systems have the option of twin rising mains. Two pumps pumping through two separate rising mains will pump approximately 50% more water than two pumps pumping through one rising main. This is very much dependent though on the pumps, pipe size and distance pumped.
3. The Titan-Pro pumping system is built with and designed to be used with pressure pipe which is tested for and supplied as suitable for pumping. The pipe inside the sump is 50 mm and terminates to a socket of 63 mm, ready for a uPVC pressure pipe rising main. A 63 mm to 50 mm reducer is supplied to allow for discharge with 50 mm pressure pipe, and this is the pipe size we recommend is to be used in the majority of cases, as 50 mm pipe can be routed across the floor within the depth of the floor insulation adjacent to the Newton BaseDrain. 63 mm pressure pipe can be used to provide better flow rates if longer pipe runs are required. If 63 mm discharge pipe is to be used, this must be confirmed at the point of order.
4. The Titan-Pro does not support 40 mm ABS waste pipe, which is not rated for pump use.

The sump chamber, with fittings and alarm can be supplied separately from the pumps if required, to allow for site installation of the sump without the pumps being left on site for extended periods.

PUMP PARTS

All parts are included within kit. NOTE: Pump is packaged in a separate box.

Included within packaging supplied with each pump are:

1. 1 x Pump
2. 1 x threaded socket to screw into the pump
3. 1 x length of 50 mm uPVC pipe
4. 1 x quick-release union with socket and male screw thread (ITEMS 2, 3 and 4 are glued together as one part)
5. 1 x 90-degree elbow with socket and female screw thread socket
6. Connecting uPVC pipe (50 mm)
7. 1 x 50 mm check valve with release union. (ITEMS 5, 6 and 7 are glued together as one part, as are Items 2, 3 and 4)

TWIN PUMP SYSTEMS HAVE TWO OF EVERYTHING MENTIONED ABOVE REGARDLESS OF WHETHER ONE OR TWO DISCHARGE LINES ARE CHOSEN

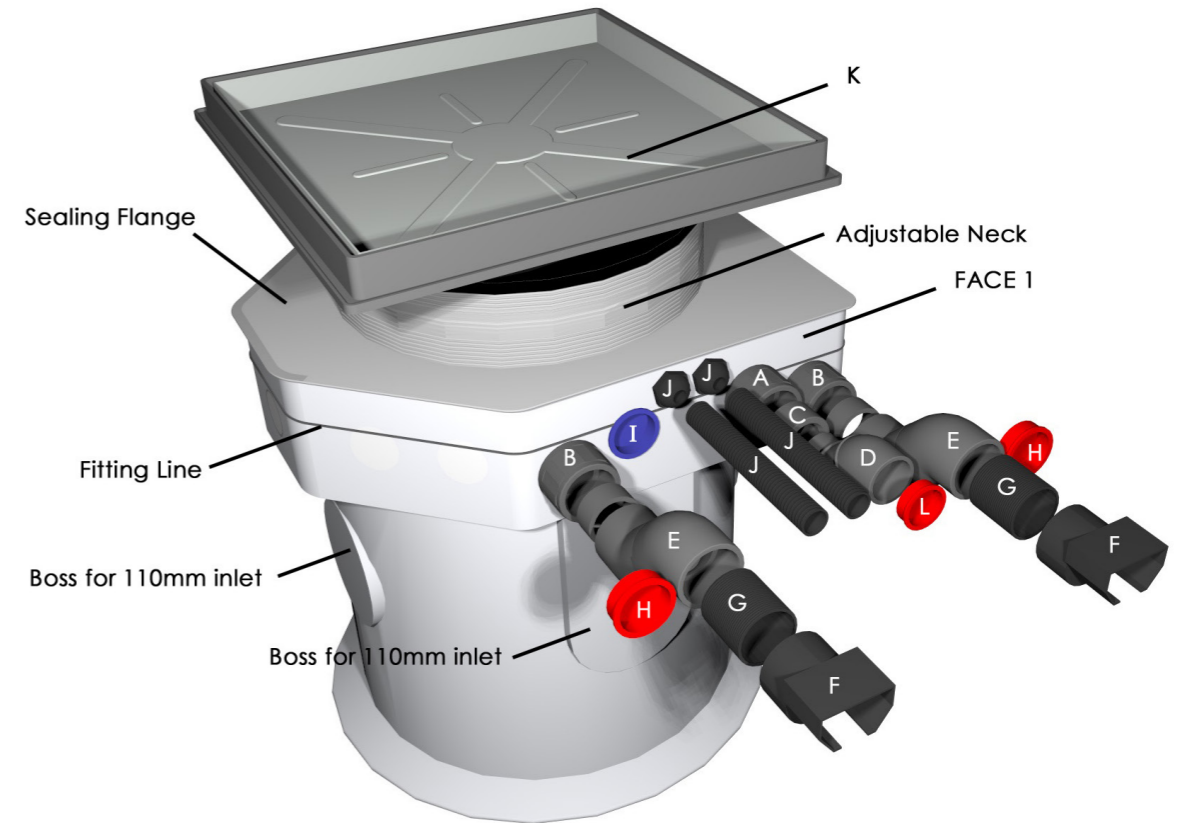
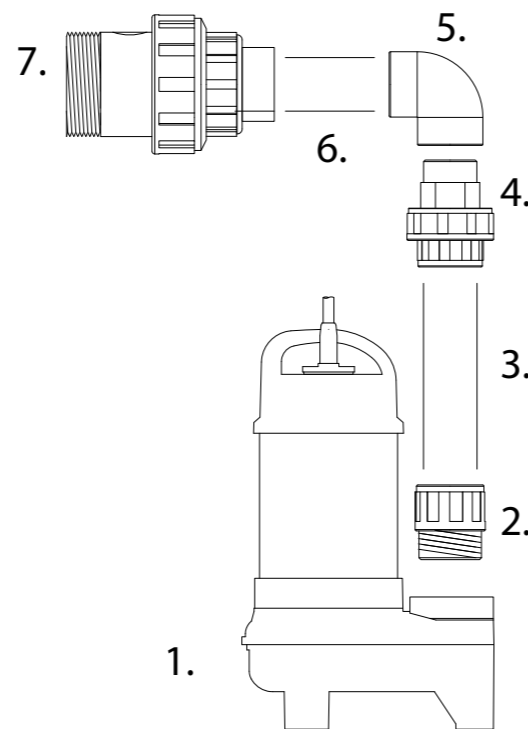

- A. 63 mm uPVC Bulk-Head fitting ready for connection of the internal and external pump pipe work:
 - i Single union for connection of single pump to Bulk-Head (where only one pump requested)
 - ii Single union for connection of twin pumps where one Bulk-Head is shared by the two pumps
- B. 2 x 63 mm uPVC Bulk-Head fittings ready for connection from the BaseDrain or FloorDrain drainage system

Included within packaging supplied with the sump are:

- C. 1 x 63 mm to 50 mm uPVC reducer (one for each discharge line)
- D. 50 mm uPVC discharge line 'S' bend for the raising of the discharge line to the slab level (one per discharge line)
- E. 2 x 63 mm uPVC Inlet line 'S' bends for the lowering of the drainage in line from the slab level to the sump
- F. 2 x Newton Drainage Adaptors for connection of Newton FloorDrain to the 63 mm drainage inlet
- G. 2 x 63 mm flexi connecting pipe for connection of the Drainage Adaptors to the 63 mm 'S' Bends of the drainage inlets
- H. 2 x 63 mm blanks for sealing the inlet to the 63 mm 'S' Bends to protect from concrete ingress during installation
- I. 1 x 60 mm blank for the blanking off of unused inlet and outlet holes drilled to the sump. When twin pumps with separate discharge pumps are ordered, this outlet will be fitted with a second Bulk-Head connection with a single union ready for the connection of the second pump.
- J. 1 x 32 mm and 1 x 40 mm, 5 m conduits and connection to sump for pump power cables and alarm cable
- K. 1 x 450 x 450 mm Polypropylene Frame with Galvanised 46 mm Recessed Lid - (alternative lids available - see page 6)
- L. 1 x 50 mm blank for sealing to pump discharge line to protect from concrete ingress during installation

NOTE: 63 mm discharge pipe option - Parts C, D and L are removed from the build and are replaced with extra 63 mm parts E and H. If 63 mm discharge pipe is to be used, this must be confirmed at order.

The Titan-Pro is designed to be used with the Newton CDM waterproofing system and receives water directly from connections to the BaseDrain Drainage System. You will need Newton BaseDrain (Product Code D1) and Newton FloorDrain (Product Code D3) to connect this sump pump system to the Newton CDM waterproofing system. **NOTE: Pipe and pipe fittings should be ordered at the same time as the pumping system as these items are not available on the high street or at builders merchants. If 63 mm discharge pipe is to be used, this must be confirmed at order.**

A number of ancillaries are available for use with the Titan-Pro:

ITEM	Product Code
uPVC Pressure Rated Discharge Pipe	
50 mm Pipe - 2.5m lengths	PP1
50 mm 90 degree elbows	PP2
50 mm 45 degree elbows	PP3
50 mm female-female sockets	PP4
50 mm Tee	PP5
50 mm wall mount clips	PP6
1½" BSP to 50 mm Hosetail	PP28
1½" BSP to 50 mm Socket	PP43
63 mm to 50 mm female reducer/adaptor	PP35
63 mm Pipe - 2.5m lengths	PP10
63 mm 90 degree elbows	PP11
63 mm 45 degree elbows	PP12
63 mm female-female sockets	PP13
63 mm Tee	PP14
63 mm wall mount clips	PP15
uPVC Solvent-on Wet 'R Dry - 240ml	G2
uPVC Pipe Primer - 473ml	G3
Alternative Frame and Lid	
Galvanised steel frame recessed lid – 600 mm x 600 mm with 450 x 450 mm opening	TPSL2
Stainless steel edged recessed lid – 600 mm x 600 mm with 450 x 450 mm opening	TPSL3
Brass edged recessed lid – 600 mm x 600 mm with 450 x 450 mm opening	TPSL4
Alulite triple-sealed recessed lid – 600 mm x 600 mm with 450 x 450 mm opening	TPSL7
General Options	
Anti-Drip Kit - extends the two drainage inlets to the bottom of the sump to prevent dripping noises	TPK1
Wet Install Kit - Includes three shut off valves	TPK6
Wall Flanges	
Wall flange for 50 mm diameter vent and conduit pipe	WF50
Wall flange for 63 mm inlet	WF63
Wall flange for 110 mm inlet	WF110
Hole Cutters	
82 mm Hole Cutter for 50 mm wall flange	HC82
95 mm Hole Cutter for 63 mm wall flange	HC95
140 mm Hole Cutter for 110 mm wall flange	HC140
Arbor for hole cutter	PA33

Further information on the Anti-Drip Kit - TPK1 is available on page 15

HEALTH AND SAFETY AT WORK

The dangers of working with water and electricity pose severe threats to health if obvious and fundamental precautions are not taken. Therefore if you are in any doubt to any of the following, please do not hesitate to contact us.

The sump installation should be undertaken by a competent person with an understanding of the Newton CDM waterproofing system and the interface of that waterproofing system with this sump system. We recommend that the Waterproofing Contractor be involved in the design of the waterproofing system including the design, installation and connection of this sump system to the waterproofing system.

The pumps should be installed by a competent person in accordance with Part P of the building regulations.

SUMP INSTALLATION - GENERAL

VERY IMPORTANT NOTE: THIS HDPE CHAMBER IS A LINER AND MUST ALWAYS BE SUPPORTED BY A CONCRETE BASE AND CONCRETE SURROUND OF ADEQUATE THICKNESS FOR THE GROUND CONDITIONS. INSTALLATION MUST BE AS PER THE FOLLOWING INSTRUCTIONS.

THE CHAMBER REQUIRES A MINIMUM OF 100 MM OF GOOD GRADE CONCRETE SURROUNDING IT TO PREVENT BUOYANCY. DECISIONS AS TO THE VOLUME AND MASS OF THE SURROUNDING CONCRETE MUST BE TAKEN BY A STRUCTURAL ENGINEER IF THE CHAMBER IS PLACED WITHIN A STRUCTURAL SLAB OR RAFT.

- 1) Select a suitable location for the chamber. Ensure that the sump lid is accessible once all the finishing works are complete. Pay particular attention to the proposed line of stud and block walls that may be built after the sump installation.
- 2) Check that no underground cables, pipes or service ducts lie beneath.
- 3) Ensure that sufficient space is available to receive the chamber, pipe work and surrounding concrete.
- 4) If water pressure exists during the installation, a method of de-watering will be required and a Wet Install Kit - TPK6 is available. Please contact Newton Waterproofing Systems for further information.

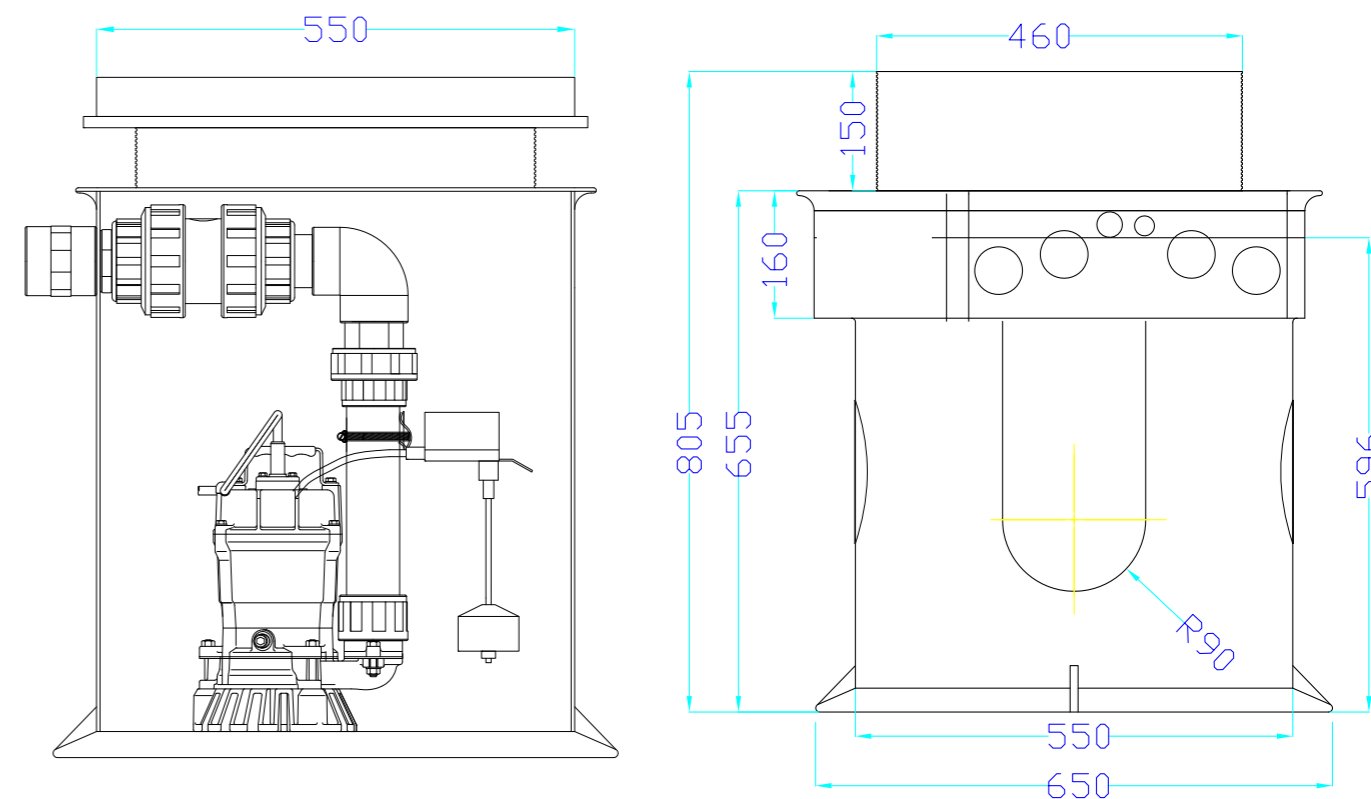

SUMP INSTALLATION - SPECIFIC

The Titan-Pro can be installed in a number of ways and the following pages include specific instructions for each of the separate methods.

STEP 1.

A. Excavate a hole within the floor ready for the sump chamber. A hole which is at least 200 mm larger in diameter than the Titan-Pro chamber will allow for sufficient concrete to surround the chamber to prevent flotation. Where the sump is to be installed within a structural slab, an engineer should advise on the volume and mass of concrete surrounding the chamber.

The chamber dimensions are shown on the previous page, but generally for a 100 mm surround of concrete the excavation will need to be 750 mm diameter x 700 mm in depth from the top of the slab, *not the top of the floor finish*. A further small rebate of 20 mm in depth and 440 mm wide, to an extent of about 350 mm out from the sump, will need to be made to the surface of the slab for the connections into the sump.

B. Prepare the sump chamber: The chamber is delivered with all inlet and outlet connections fitted to FACE 1 (see diagram on page 4) ready for a side wall installation. If the system was ordered with dual pump discharge lines, there will be two Part A Bulk Head connections. Please note that Parts H & M are not used during an installation to an existing floor slab.

B1. Fit the two 63 mm inlet 'S' Bends (Part E) into the two Bulk Head connections (Part B).

B2. Fit the discharge line 'S' Bend to the Bulk Head connection (Part A). If two discharge lines are to be used, one for each pump, fit the second 'S' Bend to the other Bulk Head connection. Do not glue at this stage.

C. When you are ready to install the chamber, create a concrete supporting base with a minimum of 100 mm of concrete which is of a consistency that will support the chamber during the levelling process. Once the concrete base is placed, go immediately to Step 2.

STEP 2.

D. Place the sump chamber into the excavation with the base directly on to the freshly laid concrete base. Rotate the chamber so that FACE 1 is perpendicular to the side wall you are installing to. Use a long builders level and adjust the chamber so it is level, ensuring that the Fitting Line is aligned with the top of the slab. Pour and then compact about 300 mm of concrete to the sides of the chamber and the excavation. With each 100 mm of concrete poured, place an equivalent depth of water into the sump chamber. Keep checking the level and height periodically and adjust if necessary. Let the concrete go off sufficiently so that the sump is locked in place and then go to Step 3.

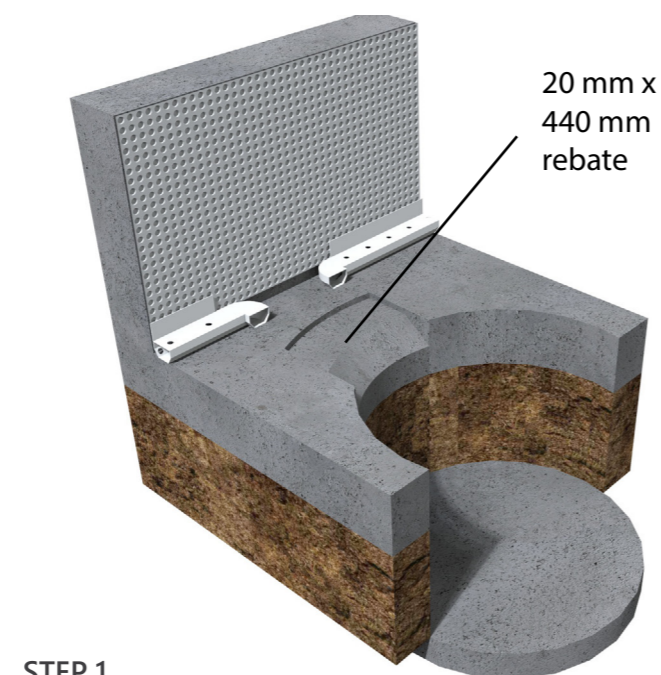

STEP 1.

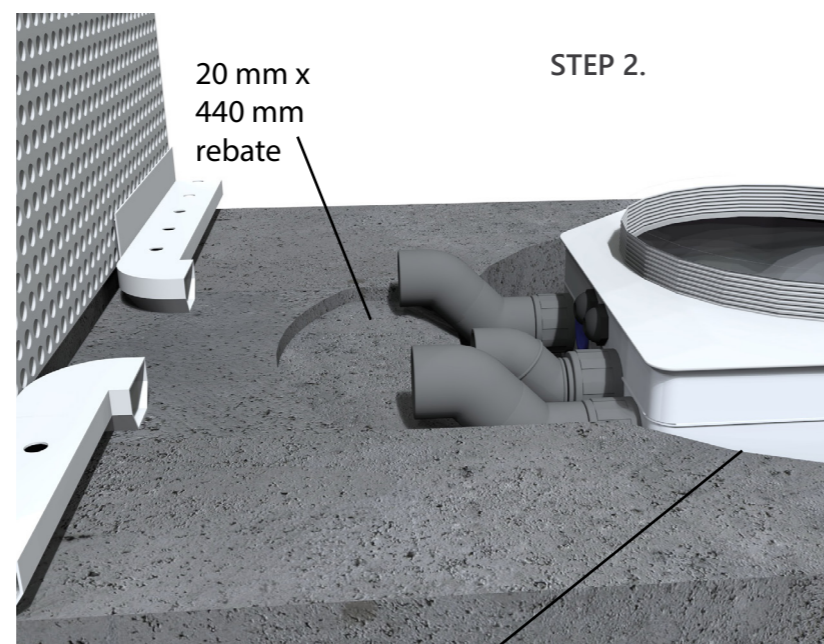

STEP 2.

The Fitting Line of the sump chamber should be level with the top of the slab

STEP 3.

E. Fit the connecting parts to the sump ready for final concreting in of the sump chamber:

E1. 1 x 40 mm and 1 x 32 mm conduit are supplied. Fit the two conduit pipes (Parts J) into the conduit wall connectors already fitted. Temporarily tape to the surface of the Newton wall membrane ready for the Pump(s) and float cables. Run the mains voltage pump cables through one conduit and extra low-voltage float cables through the other. **WARNING:** never mix mains and extra low voltage cables. The Pump Controller (CP9) uses mains voltage float cables. Do not use within the same conduit as the low-voltage Alarm cable. If the Pump(s) and Alarm are not on site, run a pull cable through the two conduits ready for pulling through the cables when they are ready to be fitted.

E2. Fit the two Newton Drainage Adaptors (Part F) to the inlet 'S' Bends (Part E) using the short lengths of ribbed 63mm pipe (Part G) to connect the parts with a push fit.

E3. Fit two cut lengths of Newton FloorDrain to the Drainage Adapter and join to the Newton BaseDrain drainage system via two BaseDrain 90-degree corners.

E4. Connect 50 mm pressure pipe to the outlet 'S' Bend (Part D). If two discharge lines are to be used, repeat for the second discharge line. Use a 90-degree elbow at the wall if the pipe is to rise vertically at this point. Continue with pipe fitting to final connection if possible, but at a minimum the vertical pipe should extend higher than the finished floor level by about 100 mm. Once all pipework is cut to the correct size, glue the pipe parts with uPVC solvent weld glue.

F. Cut the neck of the sump chamber to the correct height so that the top of the supplied Lid and Frame (Part L) match the proposed finished floor level. Place Lid and Frame onto the sump chamber ready for final concreting.

G. Fill the sump with water and then concrete around the sump to match slab. Unless the concrete contains an additive, [CDM 906 Lime Inhibitor](#) should be used within or above new concrete surrounding the chamber. When the concrete is cured, drill a ring of 6 mm holes around the chamber at 50 mm intervals to capture water that may squeeze up between the sump and the concrete surround.

STEP 4.

H. Continue with the installation of the Newton CDM System. Fill in between the inlet and outlet connections with shaped closed cell insulation. Fit the floor membrane as normal allowing the cut and shaped floor membrane to undersail the Sealing Flange of the sump chamber.

I. Seal the floor membrane to the Sealing Flange with 5 cut strips of Newton OverTape.

J. Match floor finish with the recessed Lid and Frame.

See Page 15 for pump installation instructions.

Note: BaseDrain, BaseDrain Corners, FloorDrain, OverTape and pipe parts are not included with the sump chamber but are cost options available from Newton Waterproofing.

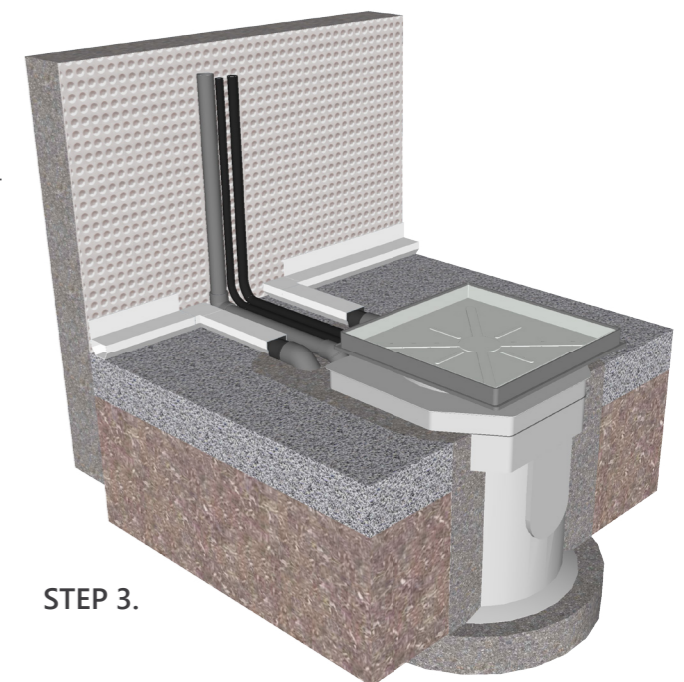

STEP 3.

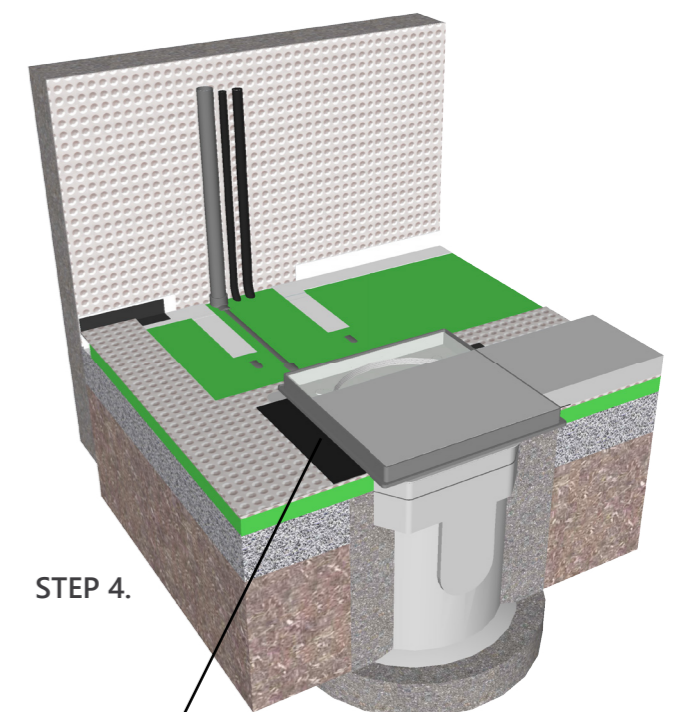

STEP 4.

Newton OverTape sealing floor membrane to Sealing Flange

STEP 1.

A. Form a concrete box to the same structural integrity as the rest of the concrete slab or raft. The box should be at least 600 mm deep x 800 mm wide. The dimension perpendicular to the wall accommodates the connections to the sump and should be 1000 mm.

B. Prepare the sump chamber: The chamber is delivered with all inlet and outlet connections fitted to FACE 1 (see diagram on page 4) ready for a side wall installation. If the system was ordered with dual pump discharge lines, there will be two Part A Bulk Head connections. Please note that Parts H & M are not used during an installation within a concrete box.

B1. Fit the two 63 mm inlet 'S' Bends (Part E) into the two Bulk Head connections (Part B).

B2. Fit the discharge line 'S' Bend to the Bulk Head connection (Part A). If two discharge lines are to be used, one for each pump, fit the second 'S' Bend to the other Bulk Head connection. Do not glue at this stage.

C. Place approximately 20 mm of fine aggregate to the centre of the base of the box. More aggregate may be required if the box is deeper than 600 mm.

STEP 2.

D. Place the sump chamber into the box with the base directly on to the fine aggregate base. Rotate the chamber so that FACE 1 is perpendicular to the side wall you are installing to. Use a long builders level and adjust the chamber so it is level, ensuring that the Fitting Line is aligned with the top of the slab.

Pour and then compact about 300 mm of concrete to the sides of the chamber and the excavation. With each 100 mm of concrete poured, place an equivalent depth of water into the sump chamber. Keep checking the level and height periodically and adjust if necessary. Let the concrete go off sufficiently so that the sump is locked in place and then go to Step 3.

STEP 3.

E. Fit the connecting parts to the sump ready for final concreting in of the sump chamber:

E1. Fit the two conduit pipes (Parts J & K) into the conduit wall connectors already fitted. Temporarily tape to the surface of the Newton wall membrane ready for the Pump(s) and Alarm cable.

Run the extra low-voltage cables through one conduit and the mains voltage through the other. If the Pump(s) and ancillaries are to be fitted at a later date run pull cables through the two conduits ready for pulling through the cables when they are ready to be fitted.

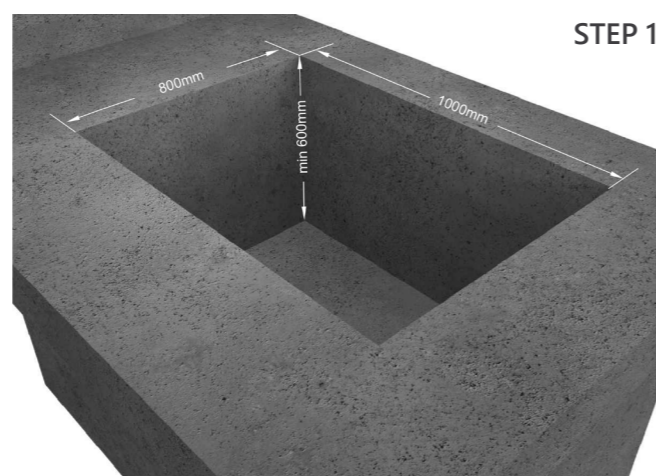

STEP 1.

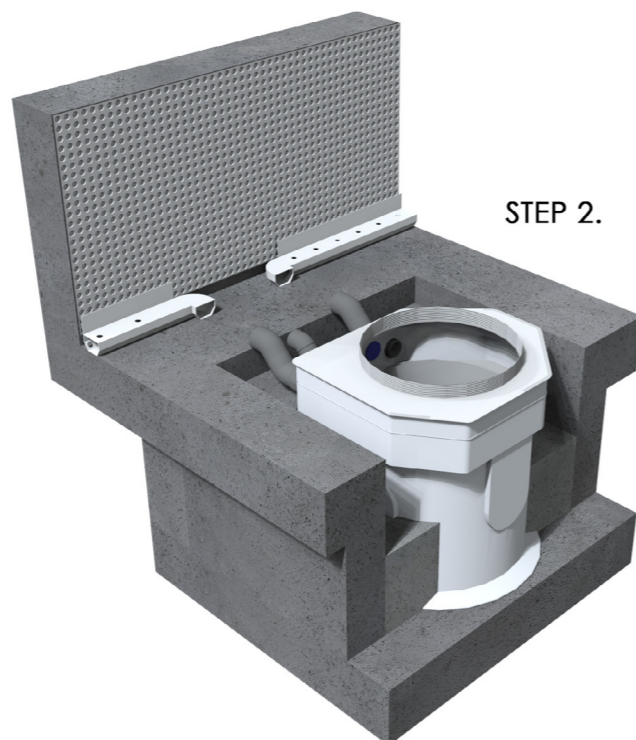

STEP 2.

E2. Fit the two Newton Drainage Adaptors (Part F) to the inlet 'S' Bends (Part E) using the short lengths of ribbed 63 mm pipe (Part G) to connect these two parts. This is a push fit - no glue required.

E3. Fit two cut lengths of Newton FloorDrain to the Drainage Adapter and join to the Newton BaseDrain drainage system via two BaseDrain 90-degree corners.

E4. Connect 50 mm pressure pipe to the outlet 'S' Bend (Part D). If two discharge lines are to be used, repeat for the second discharge line. Use a 90-degree elbow at the wall if the pipe is to rise vertically at this point. Continue with pipe fitting to final connection if possible, but at a minimum the vertical pipe should extend higher than the finished floor level by about 100 mm. Once all pipework is cut to the correct size, glue the pipe parts with uPVC solvent weld glue.

F. Cut the neck of the sump chamber to the correct height so that the top of the supplied Lid and Frame (Part L) match the proposed finished floor level. Place Lid and Frame onto the sump chamber ready for final concreting.

G. Fill the sump with water and then concrete around the sump to match slab. Unless the concrete contains an additive, [CDM 906 Lime Inhibitor](#) should be used within or above the new concrete surrounding the chamber. When the concrete is cured, drill a ring of 6 mm holes around the chamber at 50 mm intervals to capture water that may squeeze up between the sump and the concrete surround.

STEP 4.

H. Continue with the installation of the Newton CDM System. Fill in between the inlet and outlet connections with shaped closed cell insulation. Fit the floor membrane as normal allowing the cut and shaped floor membrane to undersail the Sealing Flange of the sump chamber.

I. Seal the floor membrane to the Sealing Flange with five cut strips of Newton OverTape.

J. Match floor finish with the recessed Lid and Frame.

See Page 15 for pump installation instructions.

Note: BaseDrain, BaseDrain Corners, FloorDrain, OverTape and pipe parts are not included with the sump chamber but are cost options available from Newton Waterproofing.

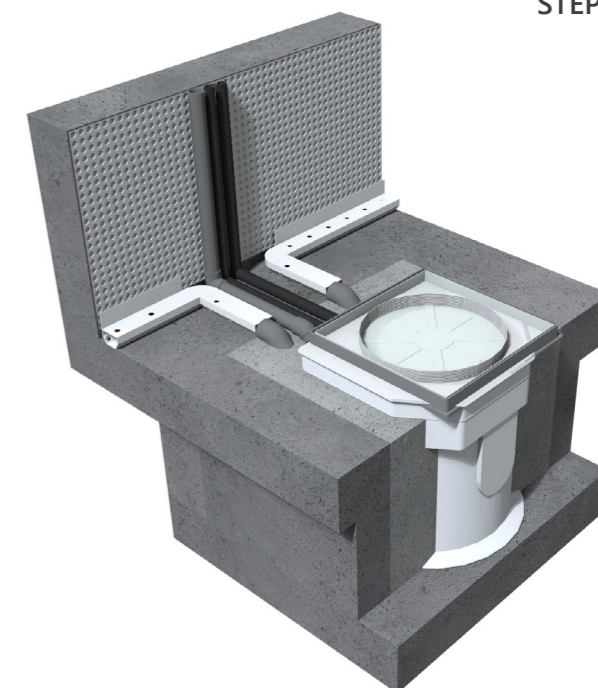

STEP 3.

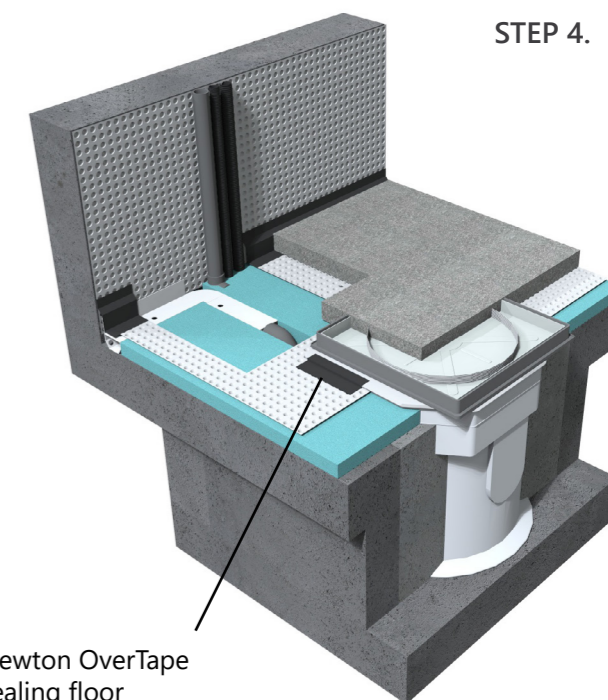

STEP 4.

Newton OverTape sealing floor membrane to Sealing Flange

For alternatives to this installation where the BaseDrain drainage system is sat within a rebate, please see Page 12.

DRAINAGE WITHIN RECESS

If the BaseDrain is sat within a formed or cut recess, this has the effect of lowering everything by 50 mm so that the Fitting Line of the sump is in line with the bottom surface of the BaseDrain/ FloorDrain and not the top of the slab.

The 100 mm x 250 mm wide recess mentioned in Step 1 Fig. 2 above will need to be deepened by 50 mm to 150 mm.

The Corner Installation can be used with the BaseDrain within the recess method.

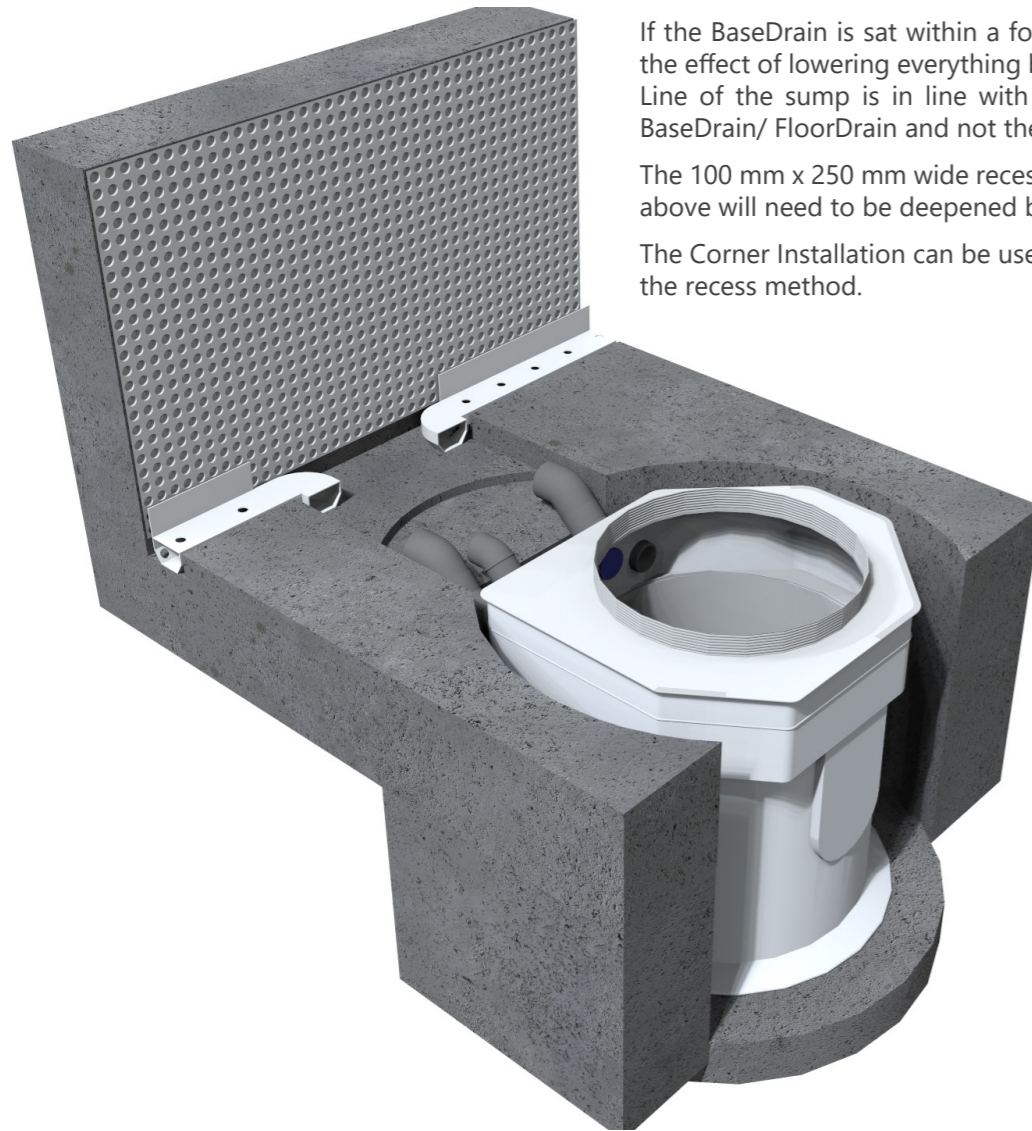

VENT

When used with the Type C, Newton CDM System with the Newton Condensation Strip fitted, the incoming drainage connection acts as a vent and so additional vents are not required.

If the system is sealed, for example where the system is providing radon measures, venting will be needed of at least 50mm O/D pipe. Unless vented outside of the building, air admittance valve(s) could be fitted.

PUMP(S) INSTALLATION

Three connection methods are available regardless of the model of pump(s) to be installed:

- a) With single pump installations, the check valve female union is connected directly to the inside wall of the sump ready for a screw connection to the check valve (Part 7).
- b) With twin pump installations terminating to one discharge line, two check valve female unions are fitted to the inside wall of the sump chamber via a two into one manifold.
- c) With twin pump installations terminating to twin discharge lines, two check valve female unions are connected separately to the inside wall of the sump chamber.

In all cases, the pipe installation of each pump is the same.

Simply screw the already glued together assembly of parts 2, 3 and 4 into the pump via the male thread of part 2, and glue part 4 into the already glued assembly of parts 5, 6 and 7 via the female socket of part 5. Use the union of part 4 to allow for rotation of the pumps within the sump for optimum position and spacing. Tighten all unions and proceed to fit the pumps as per the pump instructions.

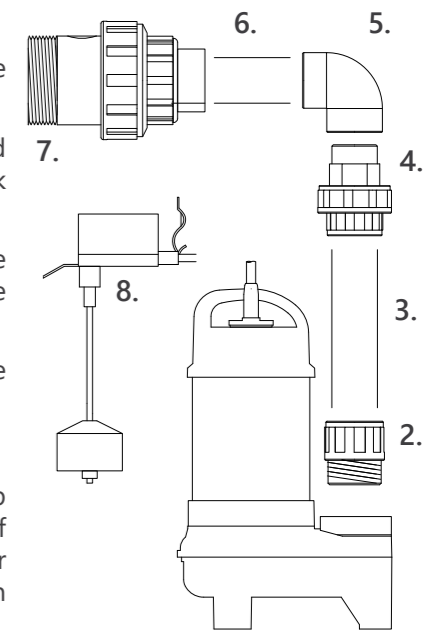

Automatic pumps are supplied with a vertical float switch (Part 8). With single pump installations, the vertical float switch should be fixed to the underside of the elbow (Part 5) with the alarm float just above the 'on' position of the vertical float to give a switching sequence of Pump, Alarm. With twin pump installations, the second float switch should be fixed to the top of the vertical pipe of the additional pump (Part 3). The alarm float switch should be fixed to the top of the vertical pipe of the first pump to give a switching sequence of Pump 1, Alarm, Pump 2. Pump control panels are supplied with 1 x vertical float switch and 1 x finger float for the alarm. Attach the floats as with a single pump installation.

Pump Controller (CP9) is supplied with 2 x vertical floats and 1 x alarm float. Attach the floats as with a twin pump installation.

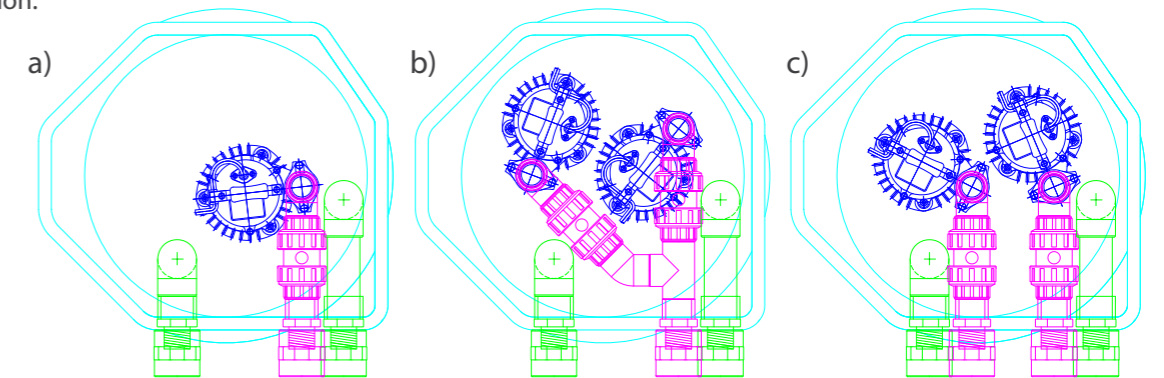

CONDUITS

2 x conduits are supplied. Use one for mains and one for extra low voltage. Do not mix voltages.

ANTI-DRIP KIT (Option)

The Anti-Drip Kit - TPK1 extends the two drainage inlet lines further into the sump chamber and then, via a 90-degree bend, vertically to almost the bottom of the sump to prevent water from the drainage channels creating a dripping sound, which can be the case when the water falls directly from the two inlets.

The two parts extensions, shown in green in the diagram b) above and adjacent are of different sizes so as to accommodate the unique shape of the sump chamber. Please fit as indicated. Each of the two extensions simply fit to the inner connection of the two inlets.

The connections should be push fitted (not glued) so that they can easily be removed for servicing.

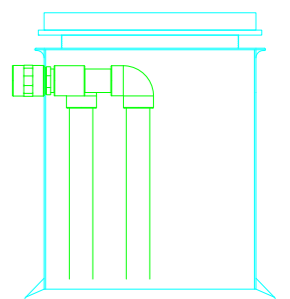

JN[®]

NEWTON WATERPROOFING



Constructionline
Gold Member

Verified Member

HEAD OFFICE

Newton House, 17-19 Sovereign Way,
Tonbridge, Kent, TN9 1RH

T: 01732 360 095
E: tech@newtonwaterproofing.co.uk
W: www.newtonwaterproofing.co.uk

Protecting Buildings Since 1848

LEEDS OFFICE

Unit 6b, Gibraltar Island Road, Old Mill
Business Park, Hunslet, Leeds, LS10 1RJ

T: 0113 521 6777
E: north@newtonwaterproofing.co.uk

JN
JOHN NEWTON
& COMPANY LIMITED (EST. 1848)
SPECIALISTS IN WATERPROOFING
AND DAMP CONTROL PRODUCTS

